

4

3

2

1

REV.	DESCRIPTION	DATE	APPROVED
-	release to production	2/17/16	obm

B



B

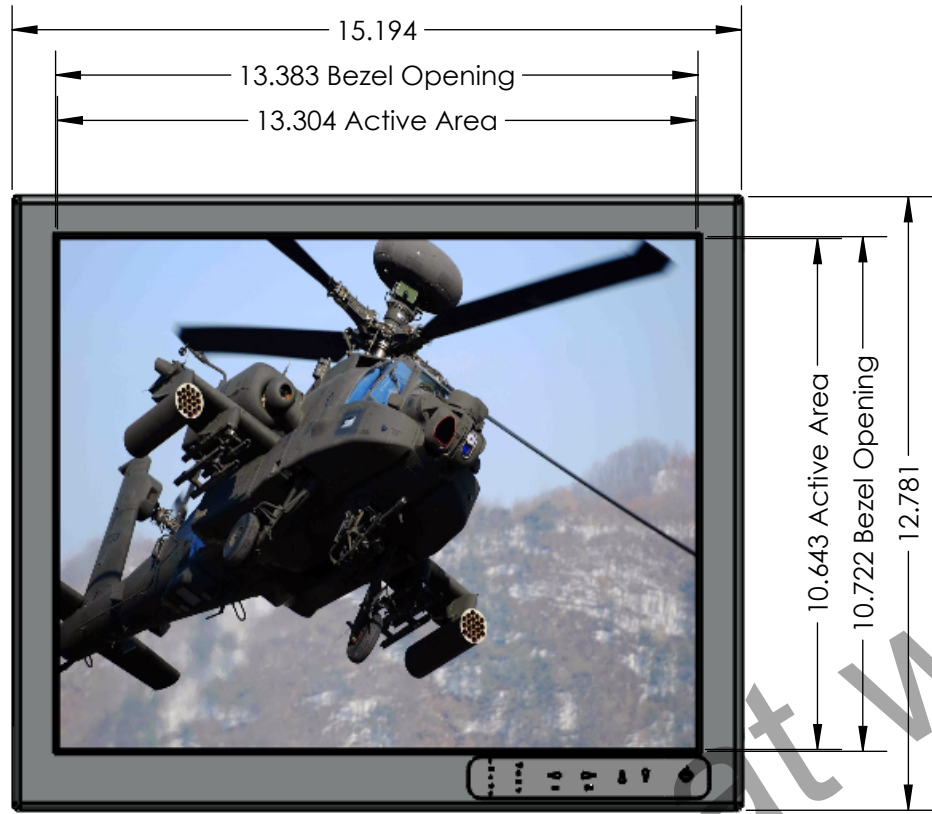

A

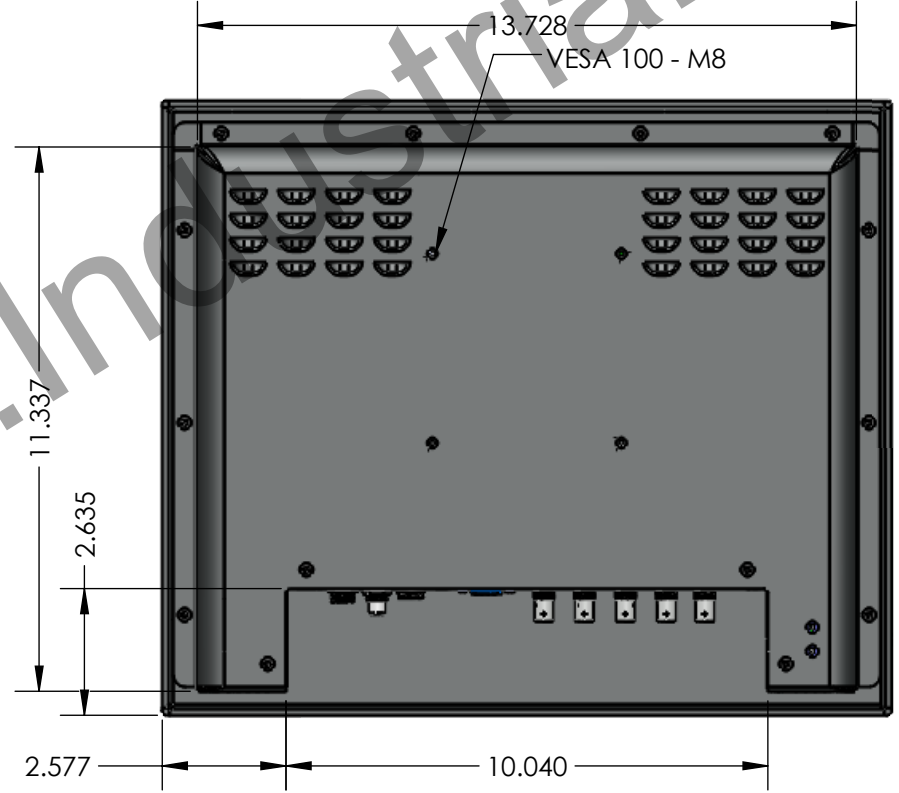
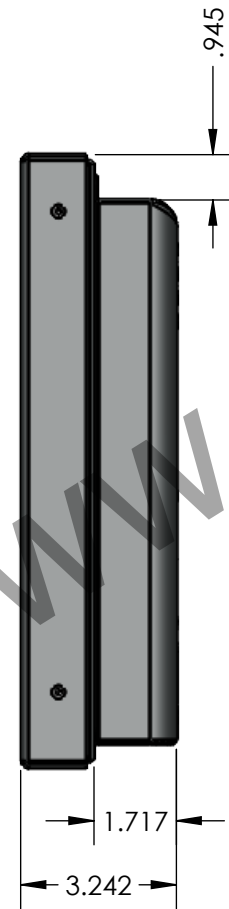

A

- NOTES:
1. FINISH: FCDT BLACK POWDER COAT (FS-001)
  2. MASS = 19.69 POUNDS
  3. TILT & SWIVEL OPTION: ERGOTRON 33-387-080
  4. ALL TRUE DIMENSIONS UNLESS OTHERWISE SPECIFIED

**PROPRIETARY AND CONFIDENTIAL**  
 THE INFORMATION CONTAINED IN THIS DRAWING IS THE SOLE PROPERTY OF DYNAMIC DISPLAY, INC. ANY REPRODUCTION IN PART OR AS A WHOLE WITHOUT THE WRITTEN PERMISSION OF DYNAMIC DISPLAY, INC. IS PROHIBITED.

UNLESS OTHERWISE SPECIFIED:		NAME	DATE
DIMENSIONS ARE IN INCHES		DRAWN	OBM 2/18/2016
TOLERANCES:		CHECKED	DR 2/18/2016
FRACTIONAL ±		ENG APPR.	OBM 2/18/2016
ANGULAR: MACH ± BEND ±.5°		MFG APPR.	TJP 2/18/2016
TWO PLACE DECIMAL ±.020		Q.A.	MRC 2/18/2016
THREE PLACE DECIMAL ±.010		COMMENTS:	
INTERPRET GEOMETRIC TOLERANCING PER:			
MATERIAL			
FINISH			
POWDER COAT BLACK WRINKLE			
DO NOT SCALE DRAWING			

Dynamic Displays, Inc.		
TITLE:		
OUTLINE DWG, 17" FLT/PNL WALL MOUNT		
SIZE	DWG. NO.	REV
<b>B</b>	0014142	01
SCALE: 1:4	WEIGHT: 19.69	SHEET 2 OF 2

4

3

2

1