

4

3

2

1

REVISIONS				
ZONE	REV.	DESCRIPTION	DATE	APPROVED
	1	PROTOTYPE RELEASE	6/11/14	OBM
	2	CHANGE LOCATION OF ITEM #5 # 9, UPDATE COMPONENTS	1/20/15	OBM
	3	CHANGE 1725478 FROM 4 PIECE ASSY TO A FULL WELDED PART.	11/4/16	OBM

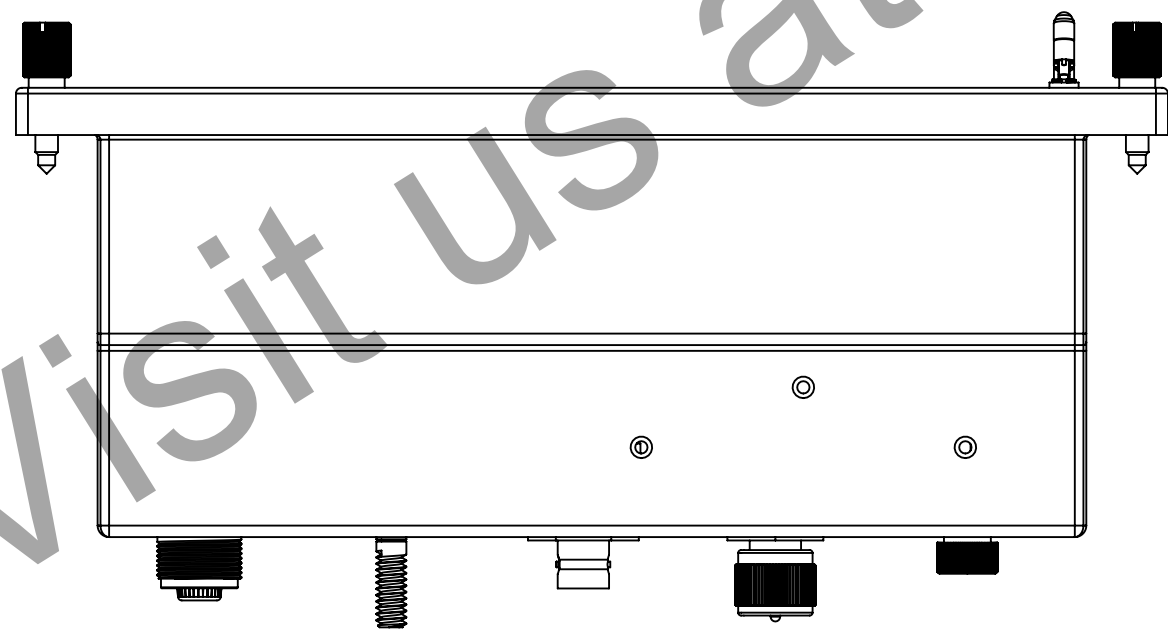
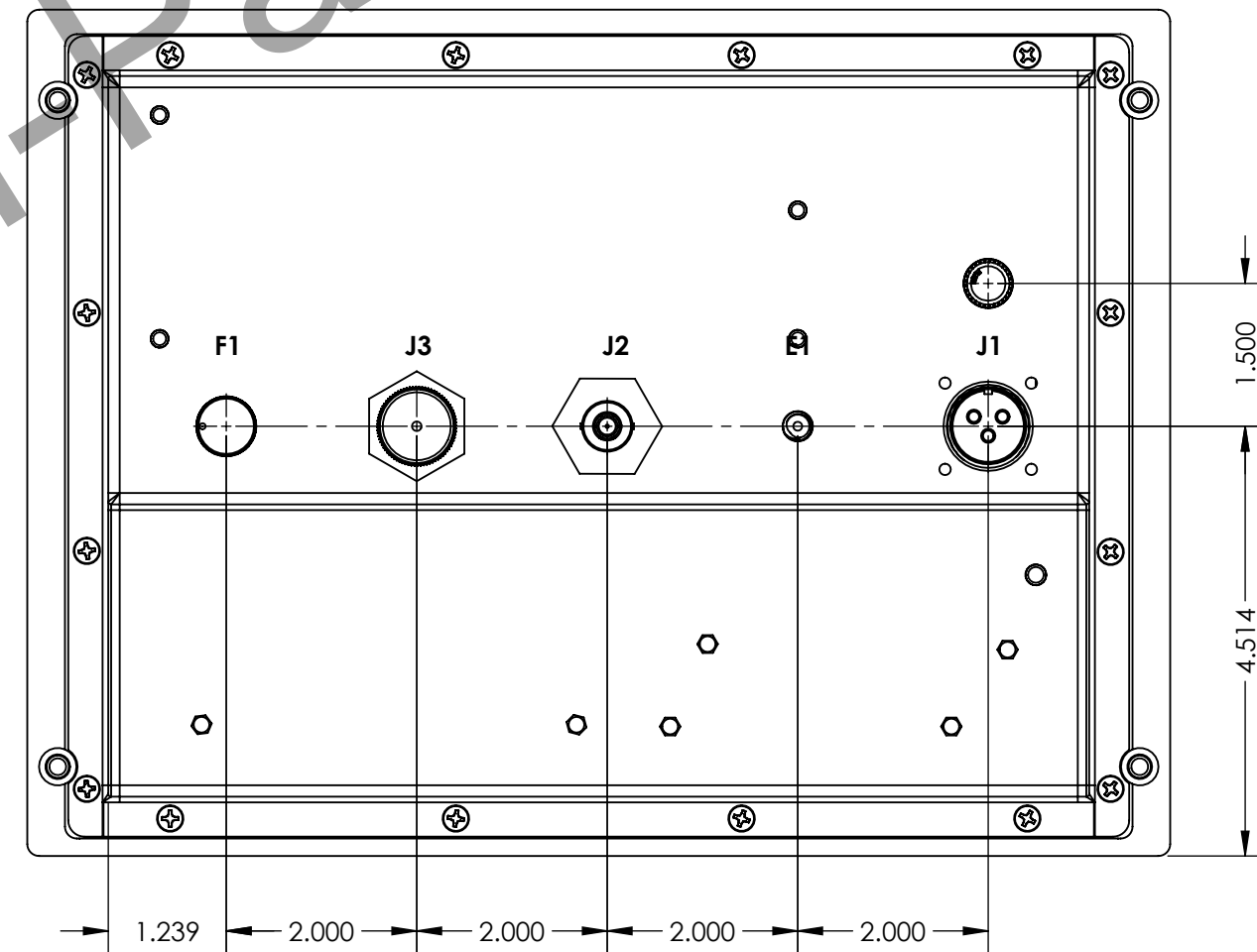
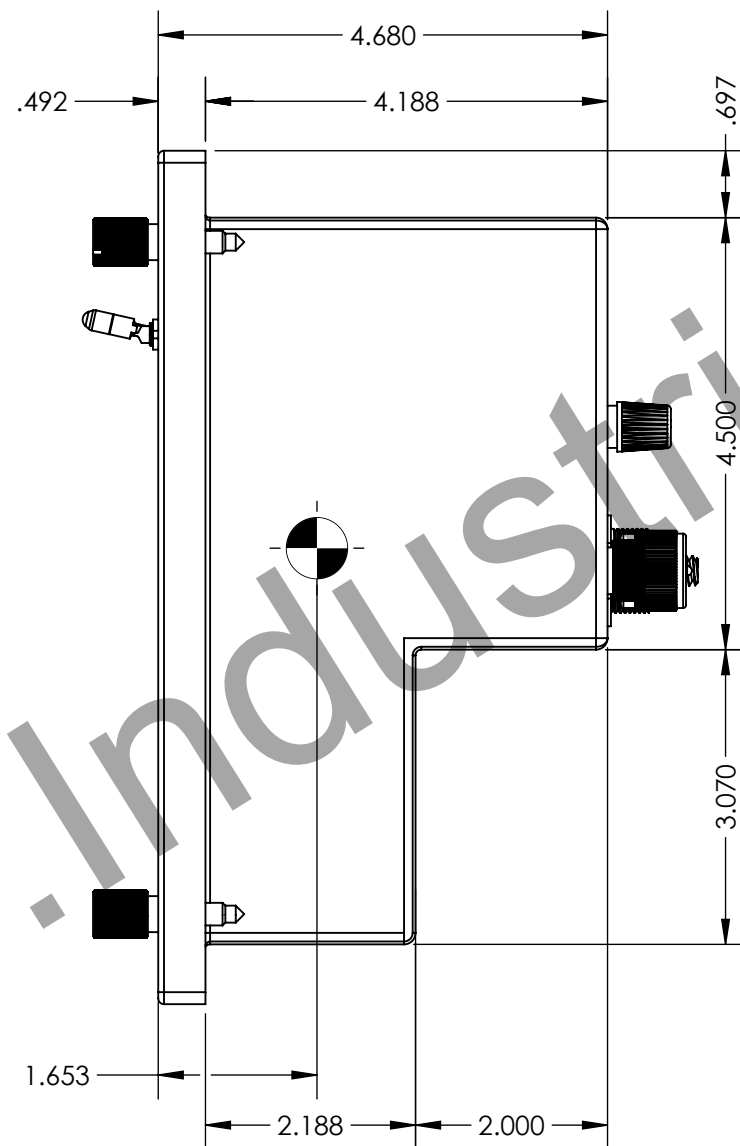
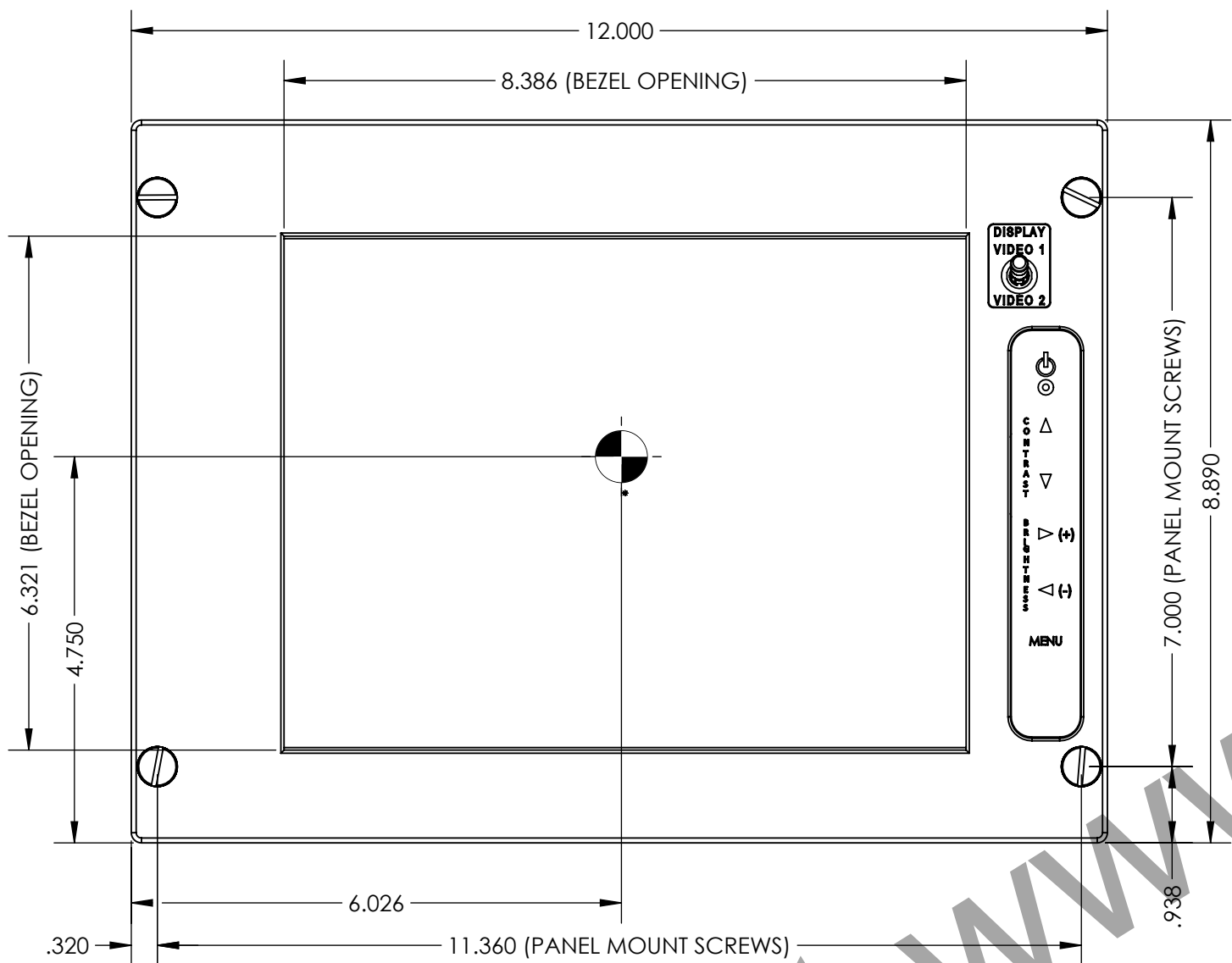
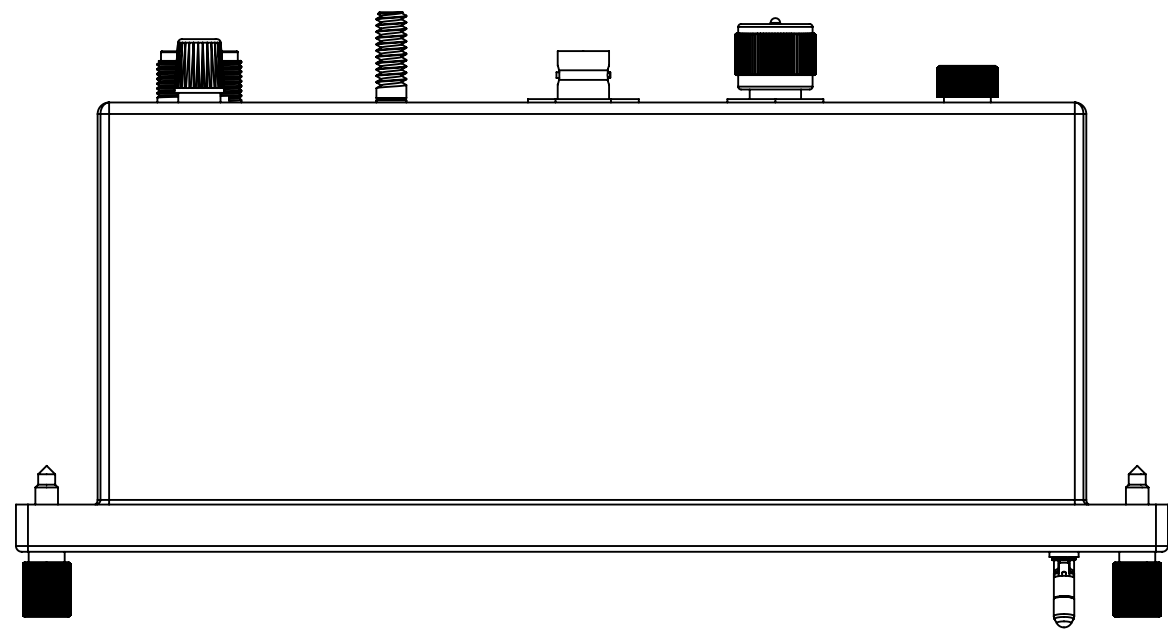

NOTES:  
 1. TOTAL UNIT WEIGHT: 9.2 Lb Calculated.

**PROPRIETARY AND CONFIDENTIAL**  
 THE INFORMATION CONTAINED IN THIS DRAWING IS THE SOLE PROPERTY OF DYNAMIC DISPLAYS, INC. ANY REPRODUCTION IN PART OR AS A WHOLE WITHOUT THE WRITTEN PERMISSION OF DYNAMIC DISPLAYS, INC. IS PROHIBITED.

UNLESS OTHERWISE SPECIFIED:	NAME	DATE
DIMENSIONS ARE IN INCHES	DRAWN	OBM 11/10/2015
TOLERANCES:	CHECKED	DR 11/10/2015
FRACTIONAL ±	ENG APPR.	OBM 11/10/2015
ANGULAR: MACH ± BEND ±	MFG APPR.	TJP 11/10/2015
TWO PLACE DECIMAL ±	Q.A.	MRC 11/10/2015
THREE PLACE DECIMAL ±	COMMENTS:	
INTERPRET GEOMETRIC TOLERANCING PER:		
MATERIAL:		
FINISH:		
DO NOT SCALE DRAWING		

DYNAMIC DISPLAYS, INC.  
 TITLE:  
**OUTLINE DWG, CRO, MONO, ASSY, 10.4"**  
 SIZE DWG. NO. REV  
**C 0014139 3**  
 SCALE: 1:2 SHEET 1 OF 2

4

3

2

1